

耒阳市亚湘电子科技有限公司

承 认 书

SPECIFICATION FOR APPROVAL



客 户 customer	思科飞尔		
产品品名: Description	YXdip2005-AG		
客户料号 PartNumber			
规格/型号 specification	100M网络变压器		
日 期 Date:	2017/2/17		
备 注 Remark:	A0 版本		
供应商	制作/日期	审核/日期	批准/日期
客户	承认/日期	审核/日期	批准/日期

TEL/电话: 0734-4308381 FAX/传真: 0734-4223263
E-MAIL/邮箱: Fmgongliangyx_tek@163.com
ADDRESS/地址: 湖南省耒阳市五里牌工业大道C5栋



INDEX

1. Index-----	1
2. Record of Revision-----	2
3. Mechanical drawing-----	3
4. Schematic drawing -----	4
5. Sample Test Report-----	5
6. Packing info-----	6
7. Recommended Wave soldering temperature curve-----	7
8. Material Certificate List&UL certification-----	8

2. Schematic:

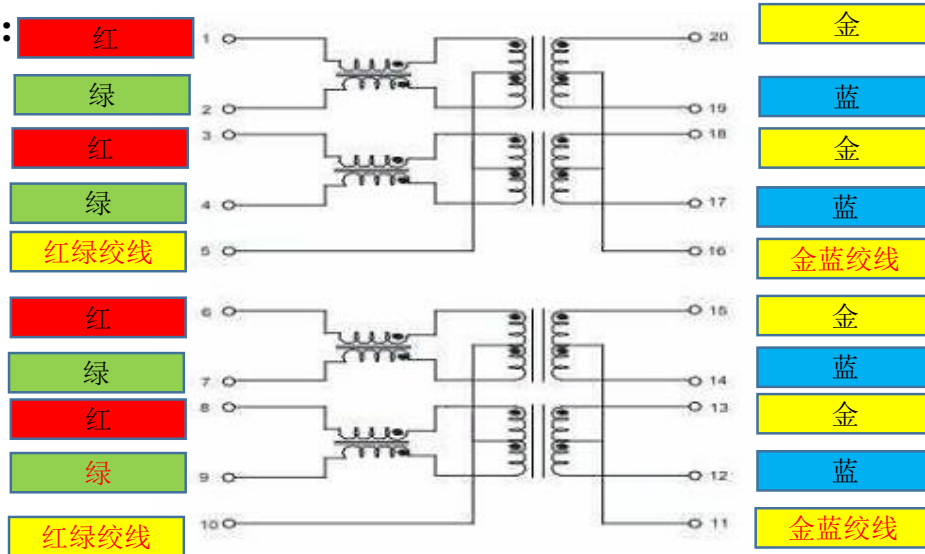

3. Electrical Specification @25°C

Open circuit Inductance:	350uH Min @ 100KHz	0.1V	8mA	DC	BIAS
Leakage Inductance:	0.50uH Max @ 100KHz	0.1V			
Interwinding Capacitance:	56pF Max @ 100KHz	0.1V			
DC Resistance:	1.2Ω	Max			
Turn Ratio:	1CT:1CT(TX)/1CT:1CT(RX)±3%				
Polarity:	1-20,4-17,6-15,9-12 In-Phase				
Insertion Loss:	0.5-100 MHz			-1.1dB	Max
Return Loss	0.5-30 MHz			-18dB	Min
	30.1-60MHz			-18+20log(f/30)	dB Min
	60.1-80MHz			-12dB	Min
Cross Talk:	0.5-40MHz			-35dB	Min
	40.1-100MHz			-33+20*log(f/50)	dB Min
CMRR:	0.5-100MHz			-30dB	Min
Isolation HI-POT:	1500VAC	1mA,1S			
Operating Temperature:	0°C to 70°C				
Product Type:	Green Product				

A. MECHANICAL (unit:mm)

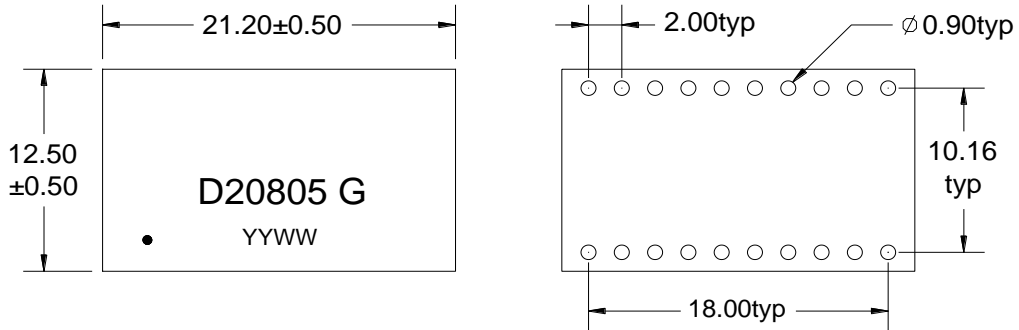

Suggested PAD layout

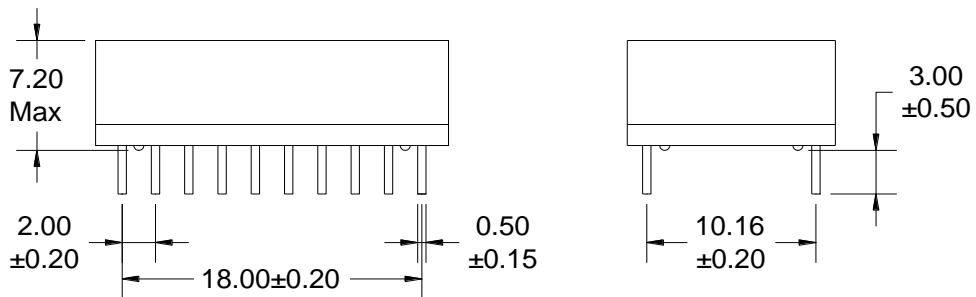

B. SCHEMATICS

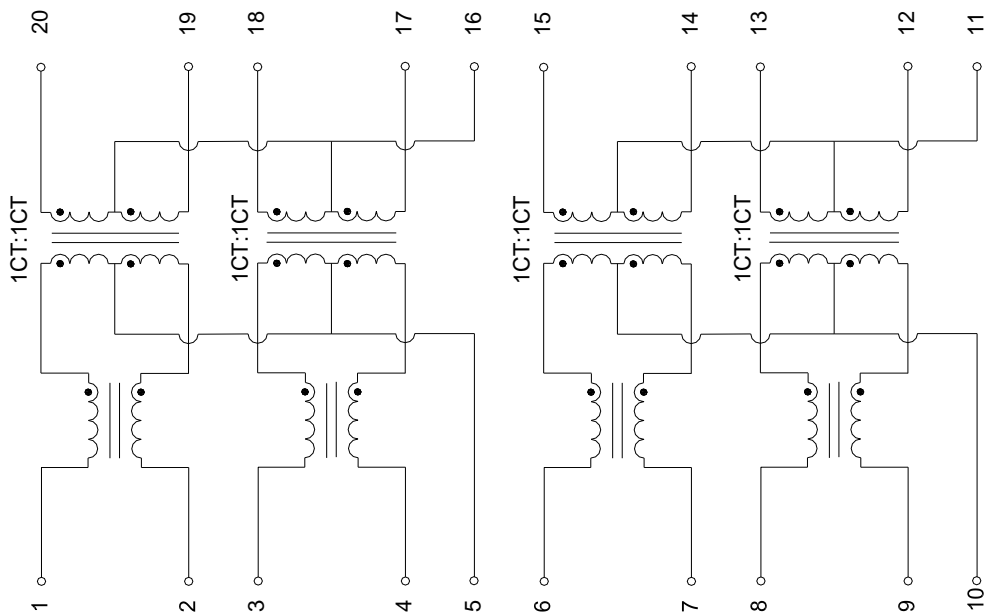

D. PACKAGE INFORMATION

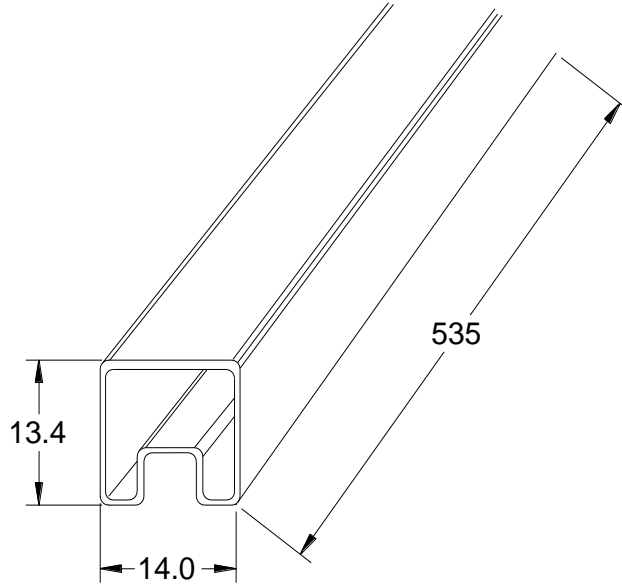

Tube: 535*13.4*14.0mm

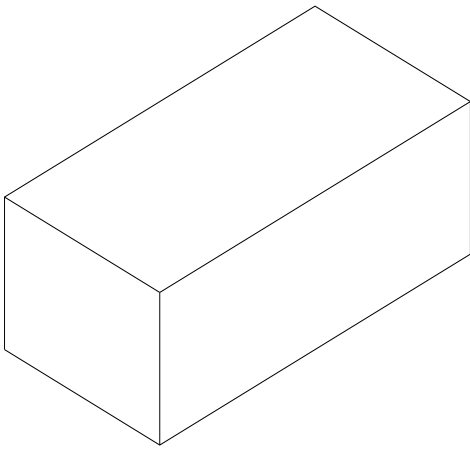

Inner Carton: L555*W165*H100mm

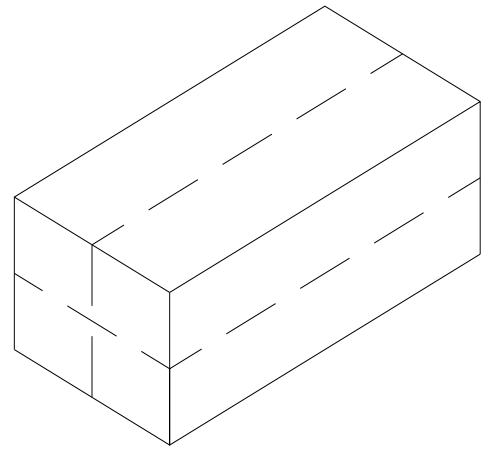

Export Carton: L570*W370*H240mm

Package Quantity:

One Tube=25Pcs

One Carton=25*20=500Pcs

One Export Carton=500*8=4000Pcs