



Yx-TEK  
亚湘科技

# APPROVED SHEET

CUSTOMER: \_\_\_\_\_

CUSTOMER P/N: \_\_\_\_\_

P/N: SMD2402 G

REV: R0

DESCRIPTION: 10/100/1000 BASE-TX

CUSTOMER APPROVAL		COMPANY APPROVAL	
			
INSPECTED BY:		ISSUED BY:	Yang.Z
CHECKED BY:		CHECKED BY:	An.L
APPROVED BY:		APPROVED BY:	Mcdull
APPROVED DATE:		ISSUED DATE:	Dec.20.2020

Please Return One Copy to Us After Approved,TKS! (承认后请回寄一份,谢谢)

## A: MECHANICAL

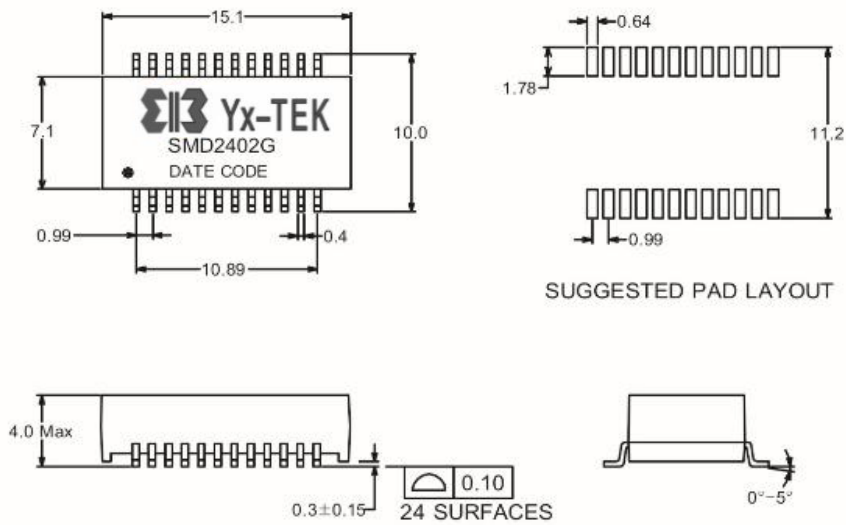

Unless otherwise specified all tolerances are: ±0.25 in mm

## B: SCHEMATICS

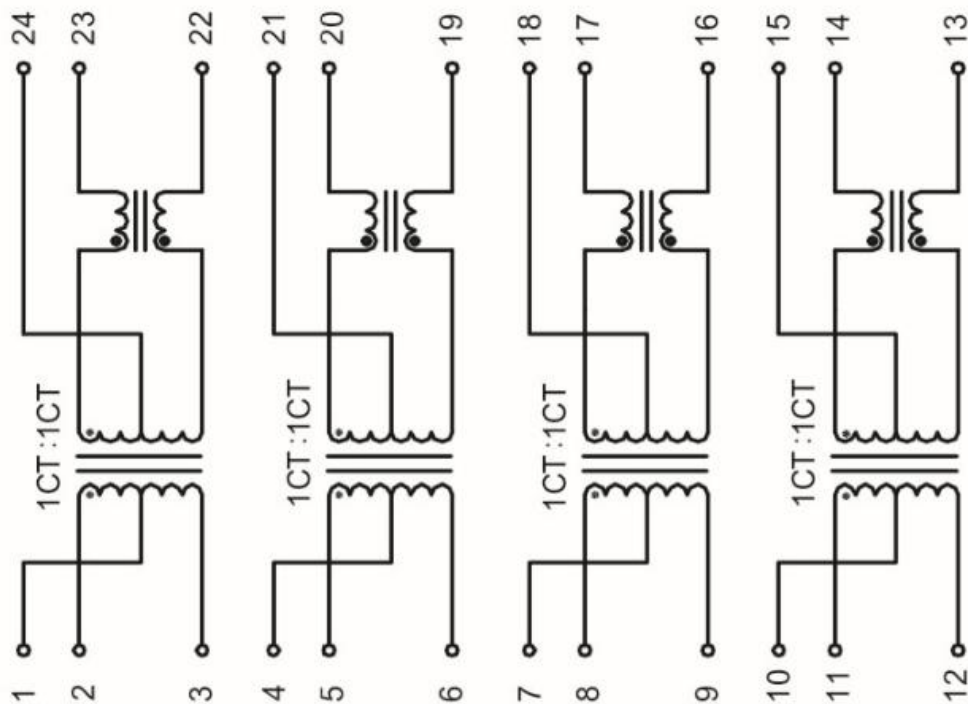

DESCRIPTION	YX P/N	SPEC NO.	REV: R0
10/100/1000 BASE-TX	SMD2402G		PAGE: 1/3

### C. ELECTRICAL SPECIFICATIONS @25°C

1. OCL: 350 uH Min @ 100 KHz, 0.1V with 8mA DC BIAS
2. Leakage Inductance: 0.5uH Max @ 100KHz, 0.1V
3. DCR: 1400mΩ Max
4. Turns Ratio: 1CT:1CT±5%
5. Insertion Loss: -1.1 dB Max @ 0.5-100 MHz
6. Return Loss: -18 dB Min @ 0.5-40 MHz  
-12+20\*log(f/80) dB Min @ 40.1-100 MHz
7. Cross Talk: -35 dB Min @ 0.5-40 MHz  
-33+20\*log(f/50) @ 40.1-100 MHz
8. Common Mode Rejection: -30 dB Min @ 0.5-100 MHz
9. Isolation Hipot: 1500VAC 1mA 60S
10. Operating temperature 0°C to +70°C
11. Storage temperature -20°C to +125°C

DESCRIPTION	YX P/N	SPEC NO.	REV: R0
10/100/1000 BASE-TX	SMD2402G		PAGE: 2/3

## D. PACKAGE INFORMATION

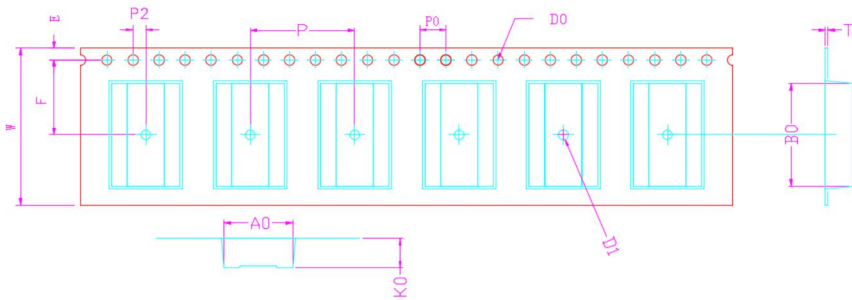

W	24.0±0.3	P0	4.00±0.1
A0	10.20±0.15	P2	2.00±0.15
A1	/	D0	1.50 + 0.1/-0
B0	15.40±0.15	D1	1.50 + 0.1/-0
B1	/	E	1.75±0.1
K0	4.90±0.1	P	16.0±0.1
	/	T	0.40±0.05
F	11.5±0.1		

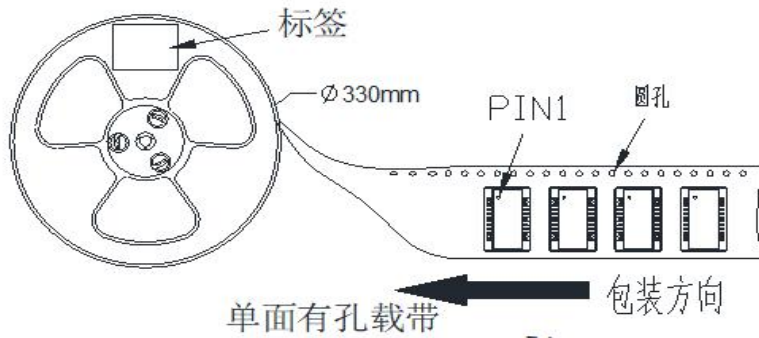

备注: 每卷载带前空15PCS格,后空15PCS格(靠近卷轴端为前)

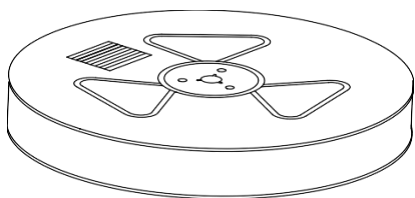

reel

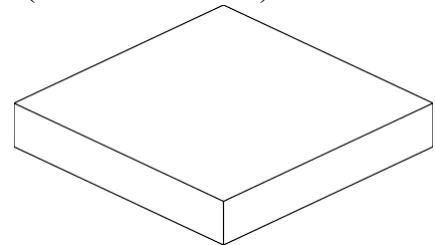

Inner Carton

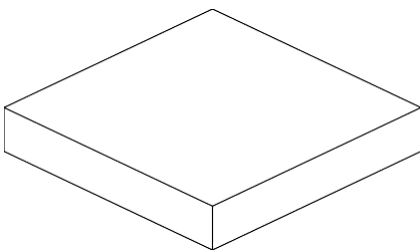

Inner Carton

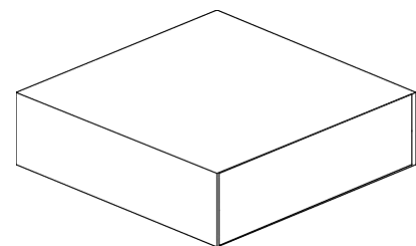

Export Carton

### Package Quantity

One Reel=800Pcs

One Inner Carton=800\*1=800Pcs

One Export Carton=800\*6=4800Pcs

DESCRIPTION	YX P/N	SPEC NO.	REV: R0
10/100/1000 BASE-TX	SMD2402G		PAGE: 3/3